

S.CS 24/L – 13.62 CEB – three-axle semitrailer with curtainsider tensioned tarpaulin design



S.CS COIL

Model: S.CS 24/L – 13.62 CEB

Technical specifications

Axles	3 x 9,000 kg
Track / Spring centre	2,040 / 1,300 mm
Disc brakes	Ø 430 mm
Wheelbase	1,410 / 1,310 mm
Premium basic tyres	385 / 65 R 22.5"
Trailer load	12,000 / 15,000 kg
Aggregate load (technical)	27,000 / 24,000 kg
Gross vehicle weight (technical)	39,000 kg
Unladen weight*	6,995 kg
Payload (technical)	32,005 kg
Overall length	13,720 mm
Overall width	2,550 mm
Internal body length	13,620 mm
Internal body width (incl. door threshold)	2,480 mm
Side through loading length	13,090 mm
Body height fr. /re. internal	2,680 / 2,780 mm
Through loading height fr. /re. internal	2,600 / 2,700 mm
Frame height fr. /re.	125 / 423 mm
Fifth-wheel height (loaded**)	1,150 mm
Rear loading height (loaded)	1,180 mm
Fully loaded height approx.	4,000 mm

* Unladen weight with spare wheel well and without additional fittings

** Other body heights are possible with different trailer coupling heights
Issued: 20.08.2006

Fittings

Chassis: bolted chassis with 10 year guarantee against rusting through of the hot galvanized parts; outer frame with curtain hook-in edge and 3 pairs of stanchion pockets; through securing holes in the outer frame; 10 pairs of securing rings in the outer frame with approx. 2,000 kg tensile force applicable per ring and up to 10 pairs with approx. 4,000 kg tensile force per ring (DIN 75410), 4 pairs of pockets for coil combi-securing posts (according to SIDMAR-regulation); coil well 9,000 x 1,250 mm

ROTOS® running gear: Trademark components with disc brake incl. EBS (electronic brake system) and RSP (roll stability program); MRH air suspension (multi-ride height); adjustment of the ramp height using central lifting /lowering device with AUTO RESET function

Lighting system: 24 volt; low maintenance, multi-chamber lights with LED tail light

Body: Aluminium bulkhead 2,400 mm high with sloping bulkhead roof, internal load protection from 750 mm high steel plate 2 aluminium rear corner posts with integral curtain tensioner; 3 pairs of slideable Schmitz Cargobull side posts with pockets for 4 rows of aluminium laths

Aluminium double hinged door: full height, with two recessed lock rods per side

Pallet floor and coil well cladding: 28 mm plywood, loadable up to 5,460 kg fork lift axle load, coil well covering using 20 inserts of 28 mm pallet floor

Schmitz Cargobull sliding tarpaulin safety roof: only 110 mm high with one piece aluminium cant rail; hydraulic FLEXOS® roof lift, to lift each side individually for loading and unloading using a manual pump

CARGOFIX sliding tarpaulins: highly loadable giving 880 g/m² with reinforced stanchions

Trailer

Services

Technology

just more.

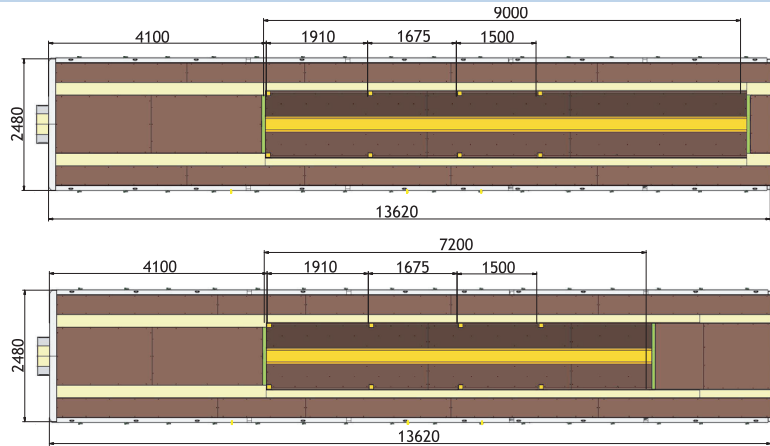

S.CS COIL

Model: S.CS 24/L – 13.62 CEB

Load distribution of different pay loads

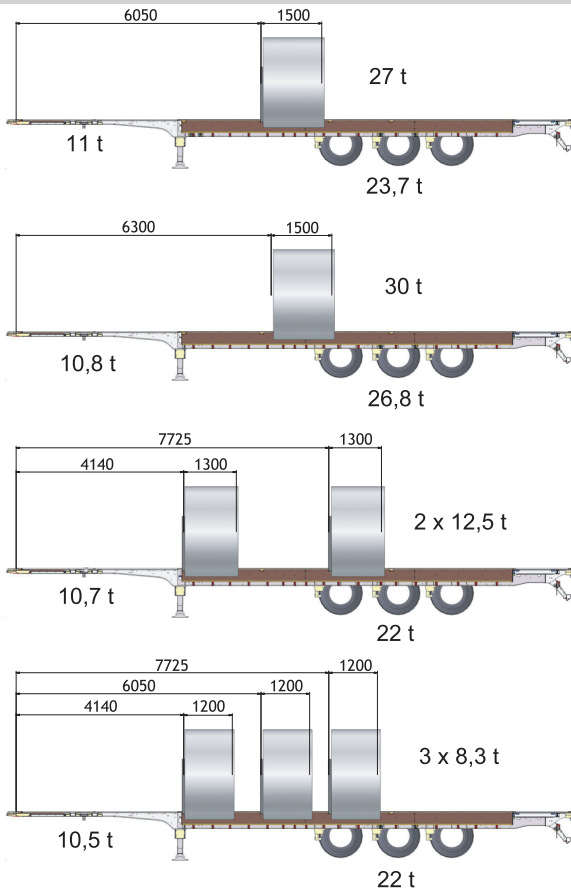

Load distribution of different pay loads

Maximum pay load = 30t at a minimum of 1.5 metres

Load distribution options with axle and king pin load for different coil weights

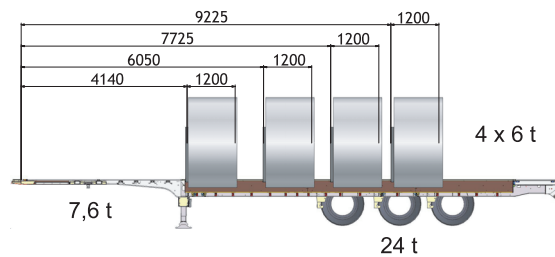

Diameter

Coil well in front view, suitable for coil diameters from 800 mm to 2,200 mm with coil securing posts

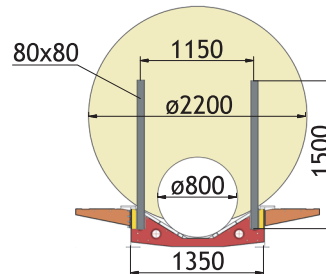

Trailer

Services

Technology

just more.